

Compact SDX[®] Nozzle

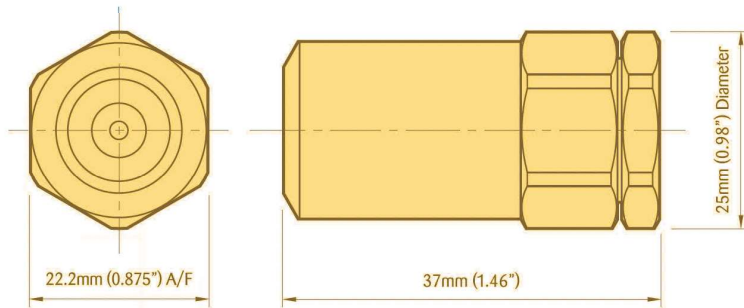

The Compact SDX[®] is a new and improved nozzle, well suited for pilot or small production spray dryers. Featuring easy to assemble, longer lasting parts, it mimics the Mini SDX[®] in size but has a higher flow range with more spray angles.

Hand tighten assembly with a maximum operating pressure of 345 BAR/5000 PSI. Maximum operating temperature to be determined by O-Ring material.

Compact SDX [®] Assembly Description and Part Numbers		
Description	Part Number	Material
(A) Body	W203010035	Stainless Steel
(B) Orifice O-Ring	A313520148	Viton
	W155100149	Silicone
(C) Orifice Disc	W20303-XXX*	Tungsten Carbide
(D) Swirl Chamber	See Swirl Chamber Chart	
(E) Swirl Chamber O-Ring	W203070013	Viton
	W203070021	Silicone
(F) Adaptor O-Ring	A313520148	Viton
	W155100149	Silicone
(G) 1/4 NPTF Adaptor	W203020034	Stainless Steel
3/8 NPTF Adaptor	W205370031	
Thread Guard	W203230013	Brass
Compact/Mini Adaptor	W214510031	Stainless Steel
Removal Tool	W203080012	Brass
Compact SDX [®] Seal Kit	(12 of each O-Ring)	
	W203050015	Viton
	W203060014	Silicone

Compact SDX [®] Swirl Chamber Part Numbers		
Ref	Part Number	Material
SA	W203040016	Tungsten Carbide
SB	W203040024	Tungsten Carbide
SC	W203040032	Tungsten Carbide
SD	W203040040	Tungsten Carbide

* Specify orifice size and swirl chamber suffix from capacity chart, on pages 24-25

Please Note: This chart is only a limited illustration of available sizes. Special materials are available on request for particular applications, please contact us for prices and delivery.



A Body



B Orifice O-Ring



C Orifice Disc



D Swirl Chamber



E Swirl Chamber O-Ring



F Adaptor O-Ring

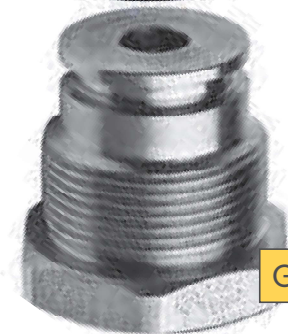

G Adaptor



Removal Tool

Part No.
W203080012.
For the removal
of Compact SDX®
Swirl Chambers and
Orifice Discs.

Assembly Procedure:

1. Place Nozzle Body **(A)** thread side up on a flat surface
2. Place the Orifice O-Ring **(B)** cone face down into the Nozzle Body **(A)**
3. Place the Orifice Disc **(C)** onto the Orifice O-Ring **(B)** protruding side down
4. Secure the Swirl Chamber O-Ring **(E)** onto the Swirl Chamber **(D)**
5. Place the Swirl Chamber Assembly **(D+E)** swirl side down onto the Orifice Disc **(C)** into Nozzle Body **(A)**
6. Secure the Adaptor O-Ring **(F)** into the recess on Adaptor **(G)**
7. Screw down the Adaptor **(G)** into the Nozzle Body **(A)** securing all components in place and hand tighten only
8. Finally ensure the complete assembly does not rattle

Seal Kits

We supply seal kits for the SDX® Nozzles in various materials. Delavan recommends that seals are changed after each run.



O-Ring Temperature Aptitude Graph (°C)

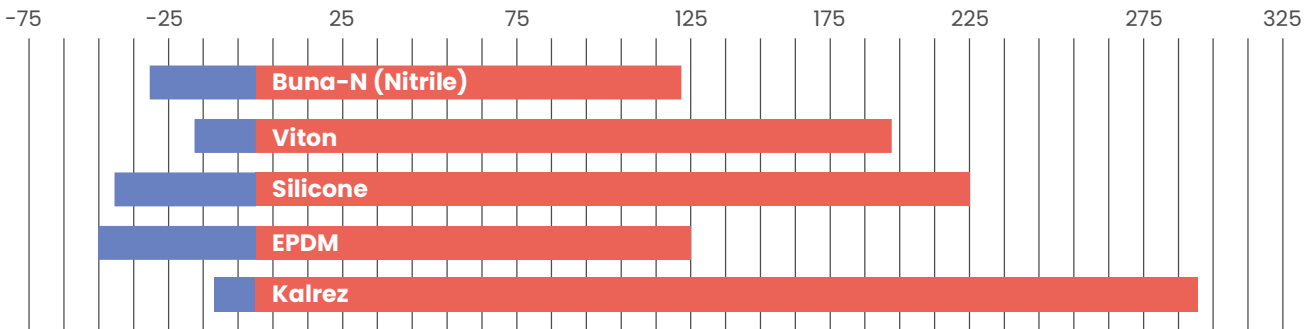

The O-ring, otherwise known as toroidal seal, is an exceptionally versatile sealing device. Delavan-supplied O-rings are of the highest quality currently available on the market and are specified specifically for our nozzle components. This data sheet offers Delavan O-ring consumers a range of performance and compatibility data from our standard supply materials. We recognise that not all applications are suitable for these standard, readily available materials and offer alternatives to suit individual applications on request. We are also able to offer FDA (Food and Drug Association) approved materials accompanied by a certificate.

SDX® Carbide Reference Guide				
Delavan Reference	Carbide Description	Abrasion	SRS Star Rating Corrosion	Erosion
Standard Grade	General Purpose Tungsten Carbide Used in all of Delavan's SDX® products and suitable for most applications	★★★	★★★	★★★
Standard Plus Grade	General Purpose Tungsten Carbide Improved resistance for use with High Pressure applications	★★★★	★★★★	★★★★
Superior Grade	Specialty Tungsten Carbide Best suited for pure Chemical Resistance with Caustic or Acid materials	★★	★★★★★	★★★★

Delavan's Star Rating System (SRS) outlines three primary properties of wear on our carbide products; abrasion, corrosion and erosion. Scale = Lowest Rating (★) to Highest Rating (★★★★★). The SDX® family of products comes with carbide internal components made from our standard grade of carbide which is noted by our part numbers. Please contact Delavan for questions on our complete line of material selections. Caution: These ratings are subject to each application and should be used as a general guide.

Maintenance Considerations

The Delavan SDX® nozzle range has been specifically designed for high pressure applications with the SDX® III configuration being in service throughout the world for over 40 years. Each component throughout the SDX® range is precision machined to tested and proven dimensions with close tolerances to suit the exacting requirements demanded by the process.

In order to ensure that the nozzles continue to operate effectively, it is vital that each component is handled carefully, ensuring that there is no damage to the components. This is particularly important with the sealing surface areas and the threads. Any slight damage to a sealing face or surface, or to a thread profile, can potentially cause an issue. If there is any doubt about the condition of a component, Delavan would suggest that the item is replaced.

The Delavan SDX® range of nozzles has been operating successfully and safely throughout the world for over 60 years. In developing the SDX® range, independent high pressure cycling and proof pressure testing was commissioned in order to ensure that we can support the ever increasing demands of our customers.



Incorrect orifice and swirl chamber material selection, resulting in premature wear. For advice on material and compatibility contact Delavan.



Damage to threads on SDX® III Nozzle.

Training

The Delavan SDX® range of nozzles are fully supported in the field through organized training sessions and backed by decades of technical experience in spray drying. Delavan offers a maintenance and training program for operators and OEMs to ensure that you have all of the tools necessary for trouble free operation of your spray nozzles.

Some of the topics covered are:

- Maintenance
- Assembly / disassembly
- Inspection of carbide components, the effects of wear, and what to look out for
- Good practice guide
- Cleaning / CIP

SDX® V Spray Dry Nozzle Flow Rate Charts.

Orifice sizes ranging from 0.016" – 0.250" in increments of 0.001" swirl chambers ranging from SA (0.76mm) to SM (16mm). The orifice and swirl chamber sizes below show an example of some possible combinations. With over 220 orifice sizes and 10 swirl chamber variants allows us to find a combination to suit your droplet size, flow rate and spray angle requirements.

All spray angles are based on water at a pressure of 1000 psi (69 bar). The MINI SDX® has a nominal spray angle of 70° – 75° due to it's unique cone faced orifice.

SDX® Nozzles Range Capacity Chart

Metering Sets (Swirl Chamber/Office)				Spray Angle		Flow Rate in Liters/HR at BAR G					Flow Rate in USGPH at PSIG				
Swirl Chamber Type				Orifice	(1000 PSIG)										
Mini SDX®	Compact SDX®	SDX® SDX® III	SDX® V	Orifice Dia (in)	Measured with Water	69	138	207	276	345	1000	2000	3000	4000	5000
SW4	–	–	–	0.016	70°-75°	21	30	37	42	47	6	8	10	11	12
SW4	–	–	–	0.018	70°-75°	24	34	42	48	54	6	9	11	13	14
SW4	–	–	–	0.020	70°-75°	26	36	45	51	57	7	10	12	14	15
SW4	–	–	–	0.022	70°-75°	28	40	49	57	64	8	11	13	15	17
SW4	–	–	–	0.024	70°-75°	33	46	56	65	73	9	12	15	17	19
–	SAC	SA	SAV	0.025	68°	51	72	89	102	114	13	19	23	27	30
SW1	–	–	–	0.027	70°-75°	55	78	95	110	123	14	20	25	29	32
–	SAC	SA	SAV	0.028	71°	57	80	98	114	127	15	21	26	30	33
SW1	–	–	–	0.030	70°-75°	62	88	108	125	140	16	23	29	33	37
–	SAC	SA	SAV	0.031	74°	62	88	108	125	140	16	23	29	33	37
SW1	–	–	–	0.033	70°-75°	66	93	114	132	147	17	25	30	35	39
–	SAC	SA	SAV	0.034	77°	68	96	118	136	152	18	25	31	36	40
SW1	–	–	–	0.036	70°-75°	71	101	123	142	159	19	27	33	38	42
–	SAC	SA	SAV	0.037	79°	76	107	131	151	169	20	28	35	40	45
SW2	–	–	–	0.038	70°-75°	100	142	177	201	224	26	37	47	53	59
–	SBC	SB	SBV	0.040	76°	95	134	164	189	212	25	35	43	50	56
SW2	–	–	–	0.042	70°-75°	114	160	197	114	254	30	42	52	30	67
–	SBC	SB	SBV	0.043	78°	104	147	180	208	233	27	39	48	55	61
SW2	–	–	–	0.044	70°-75°	119	168	207	238	266	31	44	55	63	70
–	SBC	SB	SBV	0.046	80°	114	160	197	227	254	30	42	52	60	67
SW2	–	–	–	0.048	70°-75°	132	187	228	265	296	35	49	60	70	78
–	SBC	SB	SBV	0.049	81°	121	171	210	242	271	32	45	55	64	72
SW2	–	–	–	0.050	70°-75°	140	198	243	280	313	37	52	64	74	83
–	SBC	SB	SBV	0.052	82°	129	182	223	257	288	34	48.1	59	68	76
SW3	–	–	–	0.054	70°-75°	191	270	331	382	389	50	71	87	101	103
–	SCC	SC	SCV	0.055	78°	170	241	295	341	382	45	64	78	90	101
SW3	–	–	–	0.056	70°-75°	202	286	351	405	453	53	76	93	107	120
–	SCC	SC	SCV	0.058	79°	182	257	314	363	405	48	68	83	96	107
SW3	–	–	–	0.060	70°-75°	219	310	380	439	491	58	82	100	116	130
–	SCC	SC	SCV	0.061	80°	193	273	334	386	431	51	72	88	102	114
SW3	–	–	–	0.062	70°-75°	231	327	400	462	516	61	86	106	122	136
–	SCC	SC	SCV	0.064	81°	202	286	351	405	454	53	76	93	107	120

SDX® Nozzles Range Capacity Chart

Metering Sets (Swirl Chamber/Office)				Spray Angle		Flow Rate in Liters/HR at BAR G					Flow Rate in USGPH at PSIG				
Swirl Chamber Type				Orifice	(1000 PSIG)										
Mini SDX®	Compact SDX®	SDX® SDX®III	SDX® V	Orifice Dia (in)	Measured with Water	69	138	207	276	345	1000	2000	3000	4000	5000
—	SCC	SC	SCV	0.067	82°	212	300	367	424	473	56	79	97	112	125
—	SCC	SC	SCV	0.070	83°	225	318	390	450	503	59	84	103	119	133
—	SDC	SD	SDV	0.073	78°	291	413	503	583	651	77	109	133	154	172
—	SDC	SD	SDV	0.076	79°	310	439	538	621	693	82	116	142	164	183
—	SDC	SD	SDV	0.079	80°	325	462	564	651	727	86	122	149	172	192
—	SDC	SD	SDV	0.082	81°	334	477	583	674	753	89	126	154	178	199
—	SDC	SD	SDV	0.085	82°	348	492	602	696	780	92	130	159	184	206
—	SDC	SD	SDV	0.088	83°	364	515	628	727	814	96	136	166	192	215
—	—	SE	SEV	0.091	78°	469	662	814	939	1048	124	175	215	248	277
—	—	SE	SEV	0.094	79°	484	685	840	969	1082	128	181	222	256	286
—	—	SE	SEV	0.097	80°	500	708	867	999	1117	132	187	229	264	295
—	—	SE	SEV	0.100	80°	515	727	893	1029	1151	136	192	236	272	304
—	—	SE	SEV	0.103	81°	530	749	920	1060	1185	140	198	243	280	313
—	—	SF	SFV	0.106	76°	723	1022	1253	1446	1616	191	270	331	382	427
—	—	SF	SFV	0.109	76°	749	1060	1298	1499	1677	198	280	343	396	443
—	—	SF	SFV	0.112	77°	769	1086	1332	1537	1718	203	287	352	406	454
—	—	SF	SFV	0.115	77°	787	1113	1363	1575	1760	208	294	360	416	465
—	—	SF	SFV	0.118	78°	814	1151	1408	1628	1821	215	304	372	430	481
—	—	SG	SGV	0.121	73°	1003	1419	1737	2006	2244	265	375	459	530	593
—	—	SG	SGV	0.124	73°	1026	1450	1775	2051	2294	271	383	469	542	606
—	—	SG	SGV	0.127	74°	1052	1487	1824	2104	2354	278	393	482	556	622
—	—	SG	SGV	0.130	75°	1079	1525	1870	2157	2411	285	403	494	570	637
—	—	SG	SGV	0.133	75°	1105	1563	1915	2210	2472	292	413	506	584	653
—	—	SH	SHV	0.136	70°	1567	2214	2714	3134	3505	414	585	717	828	926
—	—	SH	SHV	0.14	71°	1628	2301	2820	3255	3641	430	608	745	860	962
—	—	SH	SHV	0.145	72°	1703	2407	2948	3406	3808	450	636	779	900	1006
—	—	SH	SHV	0.15	73°	1760	2490	3047	3520	3936	465	658	805	930	1040
—	—	SH	SHV	0.155	74°	1817	2570	3145	3634	4061	480	679	831	960	1073
—	—	SI	SIV	0.16	70°	2044	2892	3539	4088	4568	540	764	935	1080	1207
—	—	SI	SIV	0.165	71°	2195	3104	3804	4391	4910	580	820	1005	1160	1297
—	—	SI	SIV	0.17	72°	2347	3319	4065	4693	5246	620	877	1074	1240	1386
—	—	SI	SIV	0.175	73°	2460	3478	4262	4920	5500	650	919	1126	1300	1453
—	—	SI	SIV	0.18	74°	2555	3615	4425	5110	5712	675	955	1169	1350	1509
—	—	SI	SIV	0.185	75°	2649	3747	4587	5299	5923	700	990	1212	1400	1565
—	—	SJ	SJV	0.19	71°	3293	4656	5704	6586	7362	870	1230	1507	1740	1945
—	—	SJ	SJV	0.195	72°	3369	4765	5836	6737	7532	890	1259	1542	1780	1990
—	—	SJ	SJV	0.20	73°	3463	4898	5999	6927	7744	915	1294	1585	1830	2046
—	—	SJ	SJV	0.205	74°	3634	5136	6294	7267	8126	960	1357	1663	1920	2147
—	—	SJ	SJV	0.21	75°	3785	5352	6556	7570	8463	1000	1414	1732	2000	2236

The orifice and swirl chamber charts show an example of some possible combinations. For a nozzle combination specific to your flow rate, droplet size, and spray angle, please contact us.